

ELECTRIC DIAGRAM OF JUICER TYPE S 42.8 TRKH AG

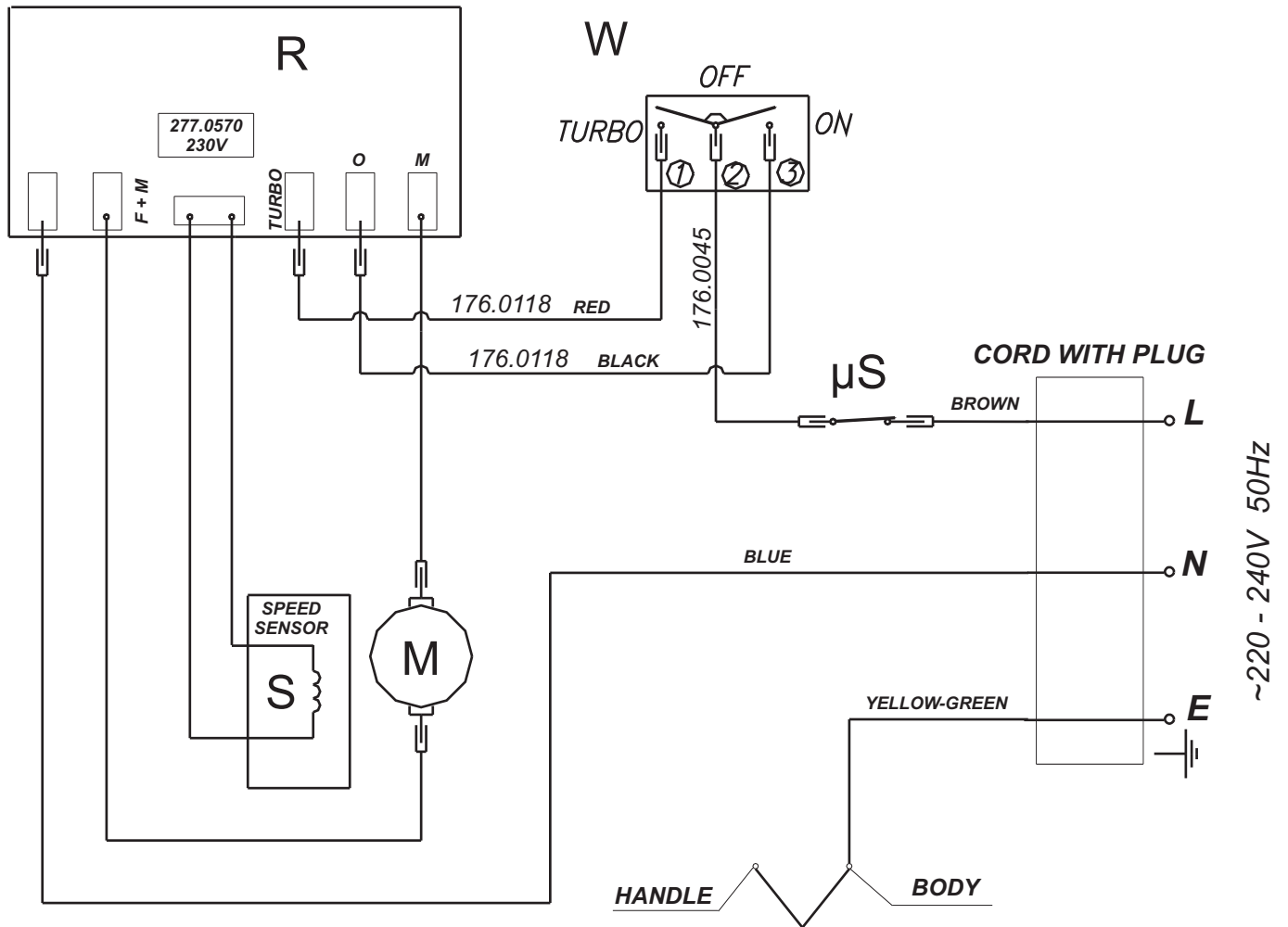

- M** - motor 388.1000
- S** - speed sensor
- W** - main switch ON/OFF/TURBO - 176.0270 (07.0413)
- R** - stabiliser 277.0570 (included speed sensor)
- μS** - microswitch 07.0523