

	Denominación	Description	Denomination
C	CONDENSADOR MOTOR	CAPACITOR MOTOR	CONDENSATEUR MOTEUR
C0	CONTACTOR GENERAL	GENERAL CONTACTOR	CONTACTEUR GÉNÉRAL
C1	CONTACTOR RESISTENCIA CALDERIN	CONTACTOR ELEMENT THERMOSTAT	CONTACTEUR RESISTANCE CHAUDIÈRE
C2	CONTACTOR RESISTENCIA CUBA	TANK ELEMENT CONTACTOR	CONTACTEUR RESISTANCE CUVE
C3	CONTACTOR BOMBA LAVADO	WASH PUMP CONTACTOR	CONTACTEUR POMPE DE LAVAGE
DD	DOSIFICADOR DE DETERGENTE	DETERGENT DOSER	DOSEUR DE DÉTERGENT
D1	REGLETA CONEXION	TERMINAL STRIP	BORNIER
EV1	ELECTROVALVULA AGUA CALIENTE	HOT WATER ELECTROVALVE	LED ELECTROVALVE EAU CHAUDE
EV3	ELECTROVALVULA REGENERACION	REGENERATION ELECTROVALVE	ELECTROVALVE REGENERATION
EV5	ELECTROVALVULA CALDERIN / VACIADO	BOILER / DRAIN ELECTROVALVE	ELECTROVALVE CHAUDIÈRE / VIDANGE
F3	FILTRO SUPRESION INTERFERENCIAS	INTERFERENCE SIPPRESION FILTER	FILTRE SUPPRESSION INTERFÉRENCES
F4	FUSIBLE	FUSE	FUSIBLE
F5	FUSIBLE ELECTROVALVULA	ELECTROVALVE FUSE	ELECTROVALVE FUSIBLE
H1	SENSOR NIVEL CALDERIN	BOILER LEVEL SENSOR	CAPTEUR DE NIVEAU CHAUDIÈRE
H2	SENSOR NIVEL CUBA	TANK LEVEL SENSOR	DETECTEUR NIVEAU CUVE
I2	DETECTOR SAL	SALT DETECTOR	DÉTECTEUR DE SEL
I3	INTERRUPTOR MAGNETICO PUERTA	DOOR MAGNETIC SWITCH	INTERRUPTEUR MAGNETIQUE PORTE
M1	BOMBA LAVADO	WASH PUMP	POMPE DE LAVAGE
M3	BOMBA VACIADO	DRAIN PUMP	POMPE DE VIDANGE
M4	DOSIFICADOR DETERGENTE	DETERGENT DOSER	DOSEUR DE DÉTERGENT
M5	BOMBA PRESION	BOOSTER PUMP	POMPE DE PRESSION
M6	DOSIFICADOR ABRILLANTADOR	RINSE AID DISPENSER	DOSEUR DE PRODUIT DE RINÇAGE
M7	BOMBA DESCALCIFICADOR	SOFTENER PUMP	POMPE ADOUCISSEUR
M8	VENTILADOR CONDENSADOR VAHOS	EXTRACTOR FAN-CONDENSER STEAM	VENTILATEUR D'EXTRACTION-CONDENSEUR DE VAPEUR
NTC1	SONDA TEMPERATURA CALDERIN	BOILER TEMPERATURE PROBE	SONDE TEMPERATURE CHAUDIÈRE
NTC2	SONDA TEMPERATURA CUBA	TANK TEMPERATURE PROBE	SONDE TEMPERATURE CUVE
NTC3	SONDA TEMPERATURA ACLARADO	RINSING TEMPERATURE PROBE	SONDE TEMPERATURE RINÇAGE
P1	PRESOSTATO	PRESSURESTAT	PRESOSTHAT
R1	RESISTENCIA CALDERIN	BOILER ELEMENT	RESISTANCE CHAUDIÈRE
R2	RESISTENCIA CUBA	TANK ELEMENT	RESISTANCE CUVE
SW1	INTERRUPTOR DESCONEXION RESISTENCIAS	ELEMENT DISCONNECTION SWITCH	INTERRUPTEUR DEBRANCHER RESISTANCE
T3	TERMOSTATO SEGURIDAD CALDERIN	BOILER SAFETY THERMOSTAT	THERMOSTAT SÉCURITÉ CHAUDIÈRE
T4	TERMOSTATO SEGURIDAD CUBA	TANK SAFETY THERMOSTAT	THERMOSTAT SÉCURITÉ CUVE
TRF1	TRANSFORMADOR MANIOBRA	OPERATION TRANSFORMER	TRANSFORMATEUR DE COMMANDE

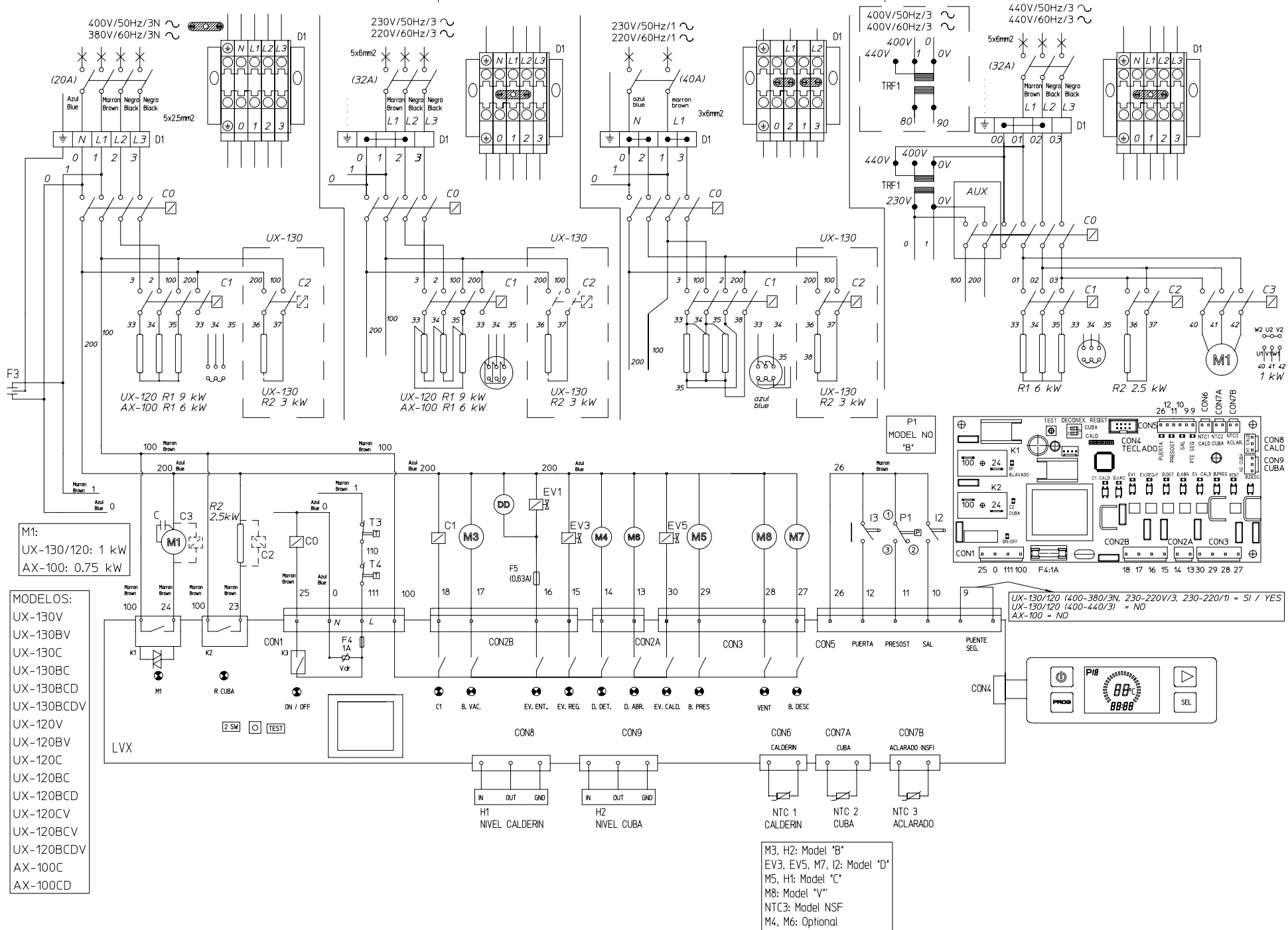

M1:
UX-130/120: 1 kW
AX-100: 0.75 kW

- MODELOS:
- UX-130V
 - UX-130BV
 - UX-130C
 - UX-130BC
 - UX-130BCD
 - UX-130BCDV
 - UX-120V
 - UX-120BV
 - UX-120C
 - UX-120BC
 - UX-120BCD
 - UX-120CV
 - UX-120BCV
 - UX-120BCDV
 - AX-100C
 - AX-100CD

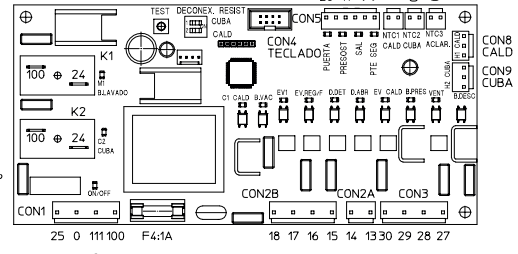

UX-130/120 (400-380/3N, 230-220V/3, 230-220/1) = SI / YES
 UX-130/120 (400-440/3) = NO
 AX-100 = NO

M3, H2: Model "B"
 EV3, EV5, M7, I2: Model "D"
 M5, H1: Model "C"
 M8: Model "V"
 NTC3: Model NSF
 M4, M6: Optional