

	Denominación	Description	Denomination
C	CONDENSADOR MOTOR	MOTOR CONDENSER	CONDENSATEUR MOTEUR
EV1	ELECTROVALVULA AGUA CALIENTE	HOT WATER ELECTROVALVE	ELECTROVALVE EAU CHAUDE
F1	FILTRO SUPRESION INTERFERENCIAS PARALELO	PARALLELINTERFERENCES SUPPRESSION FILTER	FILTRE SUPPRESSION INTERFÉRENCE PARALLÈLE
I1	INTERRUPTOR GENERAL LUMINOSO	LUMINOUS MAIN SWITCH	INTERRUPTEUR GÉNÉRAL LUMINEUSE
I2	PULSADOR LUMINOSO CICLO	LUMINOUS CYCLE BUTTON	TOUCHE LUMINEUSE CYCLE
I3	INTERRUPTOR MAGNETICO PUERTA	DOOR MAGNETIC DETECTOR	DÉTECTEUR MAGNÉTIQUE PORTE
I6	PULSADOR VACIADO	DRAINING BUTTON	TOUCHE DE VINDAGE
K0	RELE POTENCIA CALDERIN	BOILER POWER RELAY	RELAIS PUISSANCE CHAUDIÈRE
K1	RELE PUERTA	DOOR RELAY	RELAIS PORTE
L2	PILOTO MÁQUINA PREPARADA	MACHINE READY LIGHT	LAMPE-TÉMOIN MACHINE PRÊTE
M1	BOMBA LAVADO	DRAIN PUMP	POMPE DE LAVAGE
M2	PROGRAMADOR	PROGRAMER	PROGRAMMATEUR
M3	BOMBA VACIADO	DRAIN PUMP	PONPE DE VINDAGE
M4	DOSIFICADOR DETERGENTE	DETERGENT DOSER	DOSEUR DÉTERGENT
P	PRESOSTATO	PRESSURESTAT	PRESSOSTAT
R1	RESISTENCIA CALDERIN	BOILER ELEMENT	RÉSISTANCE CHAUDIÈRE
R2	RESISTENCIA CUBA	TANK ELEMENT	RÉSISTANCE CUVE
T1	TERMOSTATO CALDERIN	BOILER THERMOSTAT	THERMOSTAT CHAUDIÈRE
T2	TERMOSTATO CUBA	TANK THERMOSTAT	THERMOSTAT CUVE
T3	TERMOSTATO SEGURIDAD CALDERIN	BOILER SAFETY THERMOSTAT	THERMOSTAT SECURITÉ CHAUDIÈRE

230V/50HZ/1 ~

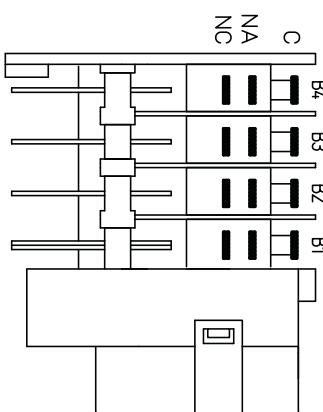
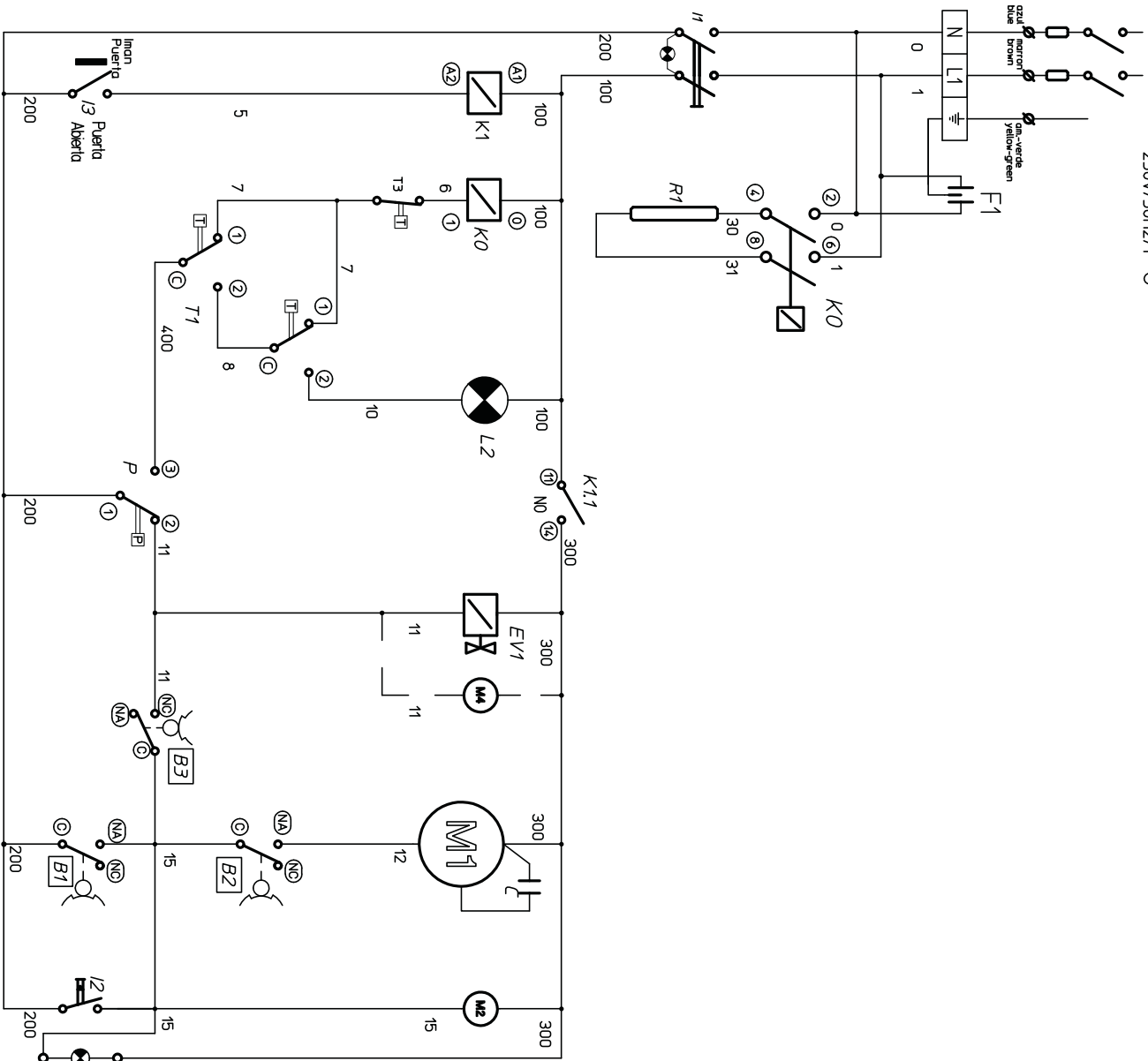

- B1: Autoalimentación
- B2: Lavado
- B3: Aclarado
- B4: Vaciado