

400V 3N ~ 50Hz

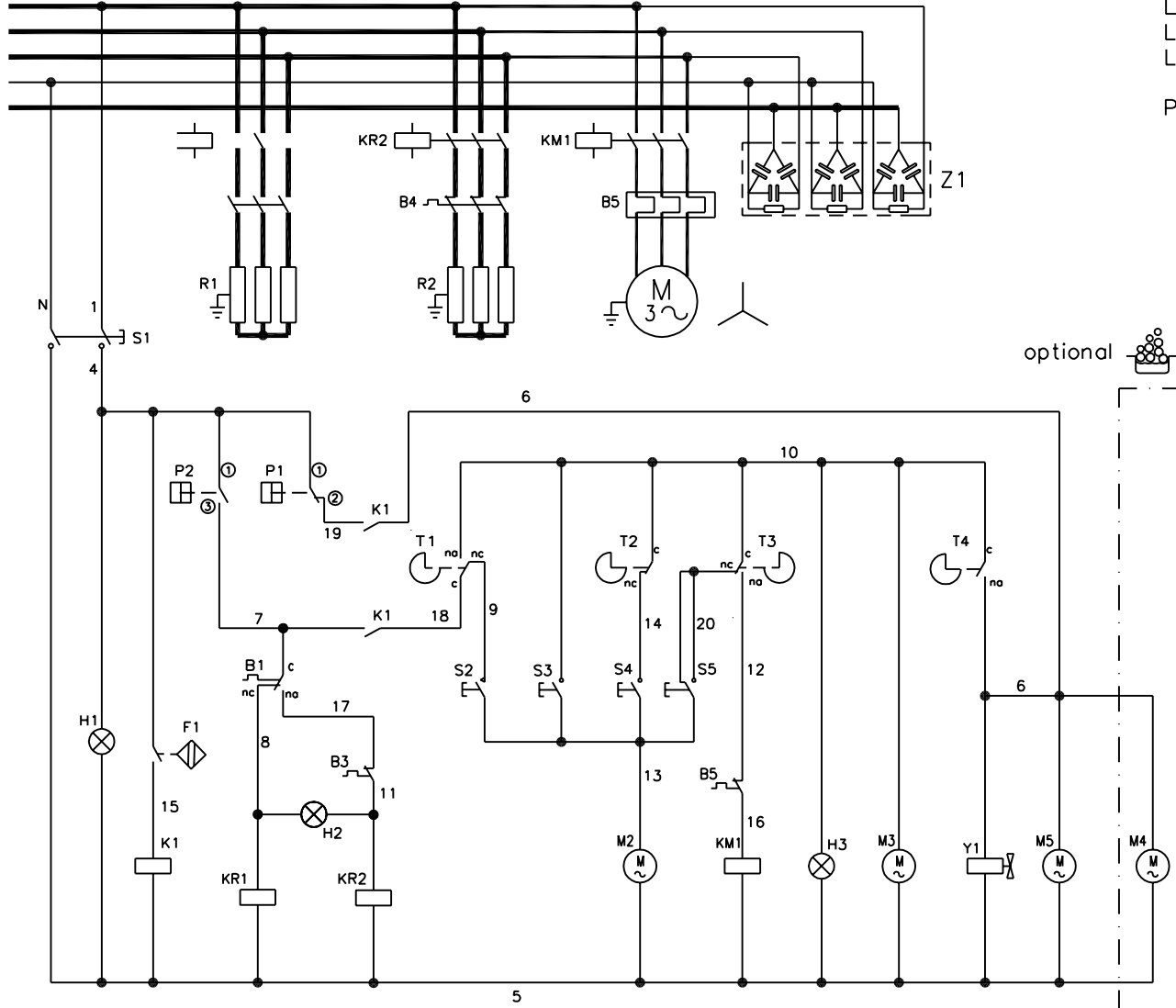

230V 3~ 50Hz

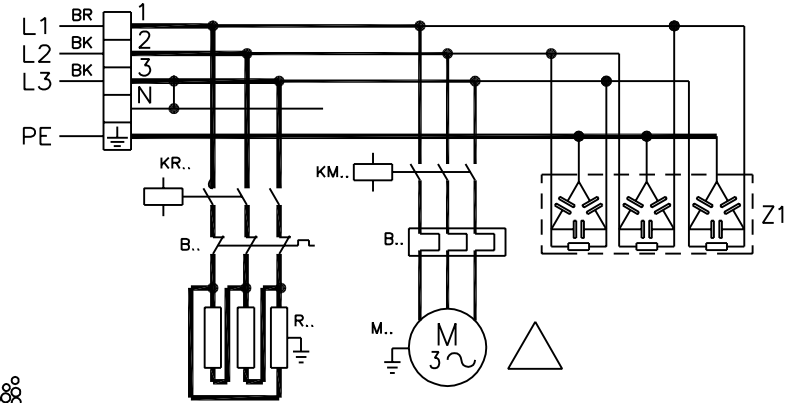

R1 max 7 kW

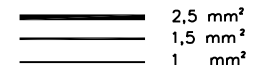

macchina spenta - porta aperta - vasca vuota  
 machine off - door opened - tank empty  
 machine desconnessè - porte ouverte - cuve vidangèe  
 Maschine aus - offene Tür - leere Wanne

TIMER A1

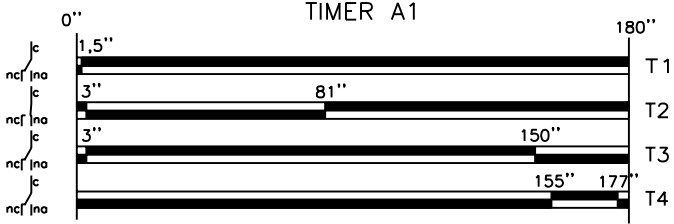

	I	GB	F	D
0-I	Interruttore principale (a carico del cliente)	Main switch (charged to the customer)	Interrupteur principal (à la charge de client)	Hauptschalter (zu Kosten des Kunden)
A1	Timer ciclo	Cycle timer	Programmateur de cycle	Programmschaltwerk
B1	Termostato boiler	Boiler thermostat	Thermostat surchauffeur	Thermostat Durchlauferhitzer
B2	Termostato sicurezza boiler	Boiler safety thermostat	Thermostat sécurité surchauffeur	Sicherheitsthermostat Durchlauferhitzer
B3	Termostato vasca	Tank thermostat	Thermostat cuve	Tankthermostat
B4	Termostato sicurezza vasca	Tank safety thermostat	Thermostat sécurité cuve	Tank-Sicherheitsthermostat
B5	Protezione termica salvamotore	Motor thermal protection	Protection thermiques moteur	Motor-Wärmeschutzschalter
F1	Micro porta	Door switch	Micro contact de porte	Mikroschalter Laugenpumpe
H1	Spia di linea	Power lamp	Voyant réseau	Netzkontrolleuchte
H2	Spia pronto macchina	Machine ready lamp	Voyant fonctionnement	Kontrolleuchte Betriebsbereitschaft
H3	Spia ciclo	Cycle lamp	Voyant de cycle	Kontrolleuchte Spülprogramm
K1	Relè sicurezza porta	Door security relay	Relais sécurité de porte	Sicherheitsrelais Tür
KM1	Relè pompa lavaggio	Wash pump relay	Relais de la pompe de lavage	Relais Umwälzpumpe
KR1	Relè resistenza boiler	Boiler heating element relay	Relais résistance surchauffeur	Relais Heizkörper Durchlauferhitzer
KR2	Relè resistenza vasca	Tank heating element relay	Relais résistance cuve	Relais Heizkörper Tank
M1	Motore pompa lavaggio	Wash pump motor	Moteur pompe lavage	Motor Umwälzpumpe
M2	Motore timer veloce	Quick timer motor	Moteur programmateur rapid	Programmschaltwerk schneller Motor
M3	Motore timer lento	Slow timer motor	Moteur programmateur lent	Programmschaltwerk langsamer Motor
M4	Dosatore detergente	Detergent pump	Pompe produit lavage	Dosiergerät Spülmittel
M5	Motore pompa risciacquo	Rinse booster pump motor	Moteur pompe auxiliaire	Motor Drucksteigerungspumpe
P1	Pressostato livello vasca	Tank pressure switch	Pressostat niveau cuves	Druckschalter Tankstandregler
P2	Pressostato protezione resistenza vasca	Tank heating protection pressure switch	Pressostat protection résistance cuve	Druckschalter Vorspültank
R1	Resistenza boiler	Boiler heating element	Résistance du surchauffeur	Heizkörper Durchlauferhitzer
R2	Resistenza vasca	Tank heating element	Résistance de cuve	Heizkörper Tank
S1	Interruttore di linea	Line switch	Interrupteur de ligne	Hauptschalter
S2	Pulsante avvio ciclo	Start cycle push button	Poussoir mise en cycle	Start-Taste Spülprogramm
S3	Selettore tempi breve	Short wash time selector	Sélecteur durée cycle bref	Wählschalter kurzes Spülprogramm
S4	Selettore tempi medio	Medium wash time selector	Sélecteur durée cycle moyenne	Wählschalter mittleres Spülprogramm
T1	Micro risciacquo	Rinse microswitch	Microcontact rinçage	Mikroschalter Nachspülung
T2	Micro autoalimentazione	Self-supply microswitch	Micro contact auto alimentation	Mikroschalter Selbsthaltung
T3	Micro lavaggio	Wash microswitch	Microcontact lavage	Mikroschalter Spülung
T4	Micro ciclo medio	Mean wash time microswitch	Microcontact cycle moyenne	Mikroschalter mittlere Spüldauer
U1	Morsettiera	Terminal board	Plaque à bornes	Anschlußplatte
Y1	Elettrovalvola carico/risciacquo caldo	Fill/hot rinse solenoid valve	Electrovanne remplissage	Magnetventil Füllung/Nachspülung warm
Z1	Filtro antidisturbo	Interference suppression filter	Filtre antiparasite	Funkenstörfilter