

	Denominación	Description	Denomination
<b>C1</b>	CONTACTOR BOMBA VACIO	VACUUM PUMP CONTACTOR	CONTACTEUR POMPE À VIDE
<b>C2</b>	CONTACTOR TRANSFORMADOR SOLDADURA	SEAL TRANSFORMER CONTACTOR	CONTACTEUR TRANSFORMATEUR DE SOUDURE
<b>C3</b>	CONTACTOR SOLDADURA PLUS	PLUS SEAL CONTACTOR	CONTACTEUR SOUDURE PLUS
<b>C31</b>	CONTACTOR SOLDADURA PLUS	PLUS SEAL CONTACTOR	CONTACTEUR SOUDURE PLUS
<b>D1</b>	REGLETA CONEXION	CONNECTION BLOCK	BLOC DE CONNEXION
<b>EV1</b>	ELECTROVALVULA VACIO	VACUUM ELECTROVALVE	ELECTROVANNE DE VIDE
<b>EV2</b>	ELECTROVALVULA GAS	GAS ELECTROVALVE	ÉLECTROVALVE GAZ
<b>EV3</b>	ELECTROVALVULA SOLDADURA	SEAL ELECTROVALVE	ÉLECTROVALVE SOUDURE
<b>EV4</b>	ELECTROVALVULA ATMOSFERA PROGRESIVA	SOFT AIR ELECTROVALVE	ELECTROVALVE D'ATM. PROGRESSIVE
<b>EV5</b>	ELECTROVALVULA DESCOMPRESION	DECOMPRESSION ELECTROVALVE	ÉLECTROVANNE DE DÉCOMPRESSION
<b>E1</b>	RELE TERMICO	MOTOR RELAY	RALAIS MOTEUR
<b>FUS1</b>	FUSIBLE	FUSE	FUSIBLE
<b>FUS2</b>	FUSIBLE	FUSE	FUSIBLE
<b>I1</b>	INTERRUPTOR GENERAL LUMINOSO	MAIN SWITCH	INTERRUPTEUR GÉNÉRAL
<b>I2</b>	MICRO TAPA	BOARD MICROSWITCH	MICRORRUPTEUR CHOCHÉ
<b>K0</b>	RELE CONEXION RED	CONECCTION RELAY	RELAIS DE CONNEXION
<b>K1</b>	RELE BOMBA VACIO	VACUUM PUMP RELAY	RELAIS POMPE À VIDE
<b>K2</b>	RELE TRANSF. SOLDADURA	SEAL TRANSFORMER RELAY	RELAIS TRANSFORMATEUR DE SOUDURE
<b>M</b>	MOTOR	MOTOR	MOTEUR
<b>PC</b>	PLACA DE CONTROL	CONTROL CARD	CARTE COMMANDE
<b>R1</b>	RESISTENCIA SOLDADURA	SEAL ELEMENT	RÉSISTANCE DE SOUDURE
<b>R2</b>	RESISTENCIA SOLDADURA	SEAL ELEMENT	RÉSISTANCE DE SOUDURE
<b>TCL</b>	TECLADO	KEYBOARD	CLAVIER
<b>TRF1</b>	TRANSFORMADOR DE MANIOBRA	MANEUVER TRANSFORMER	TRANSFORMATEUR DE MNOEUVRE
<b>TRF2</b>	TRANSFORMADOR SOLDADURA	SEAL TRANSFORMER	TRANSFORMATEUR DE SOUDURE
<b>TRF3</b>	TRANSFORMADOR SOLDADURA	SEAL TRANSFORMER	TRANSFORMATEUR DE SOUDURE
<b>VDR</b>	VARISTOR	VARISTOR	VARISTOR

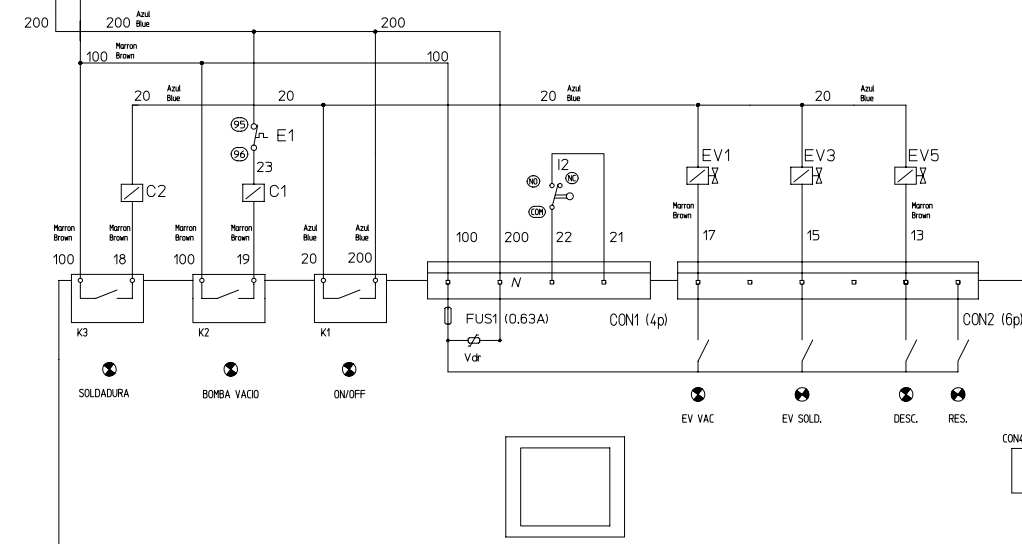

**CAMBIO DE TENSION 400V/230V**  
 1-Desconectar el neutro de la regleta de conexiones y conectar el puente suministrado.  
 2-Realizar las conexiones del motor segun se indica en la caja de bornes.  
 3-Ajustar el rele termico.

**MODELOS:**  
 SE-604. MOTOR: 11 kW  
 SE-606. MOTOR: 15 kW

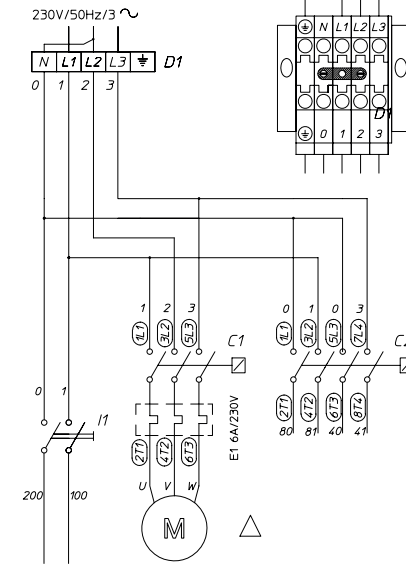
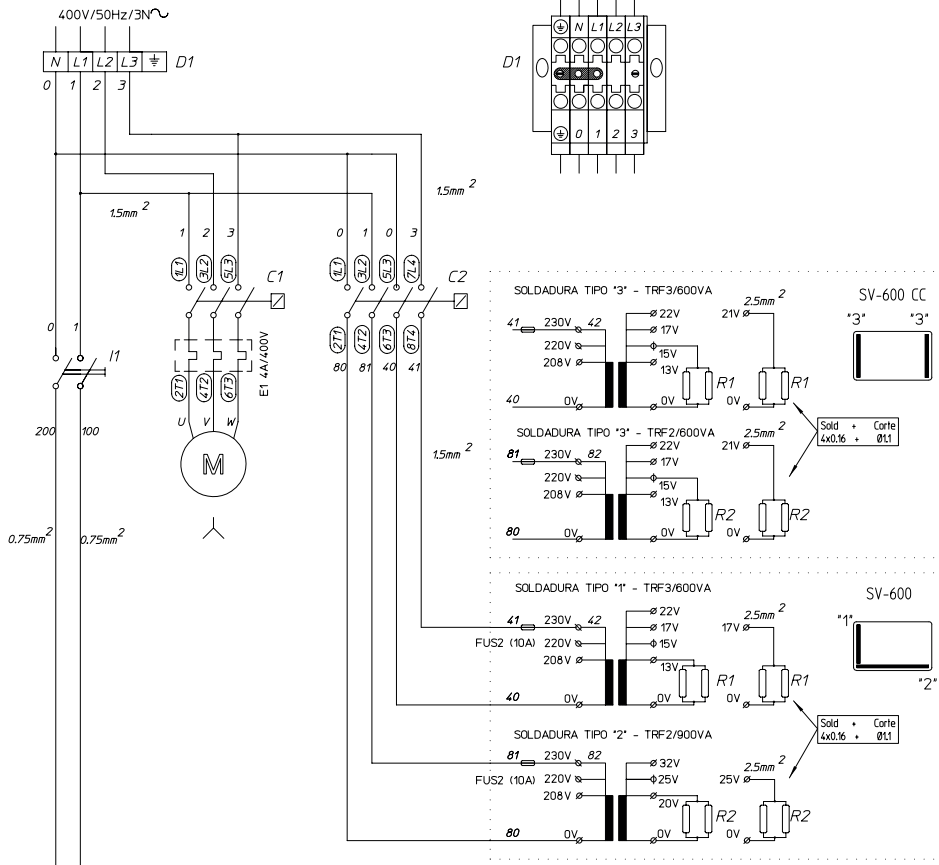