

	Denominación	Description	Denomination
<b>C1</b>	CONTACTOR BOMBA VACIO	VACUUM PUMP CONTACTOR	CONTACTEUR POMPE À VIDE
<b>C2</b>	CONTACTOR TRANSFORMADOR SOLDADURA	SEAL TRANSFORMER CONTACTOR	CONTACTEUR TRANSFORMATEUR DE SOUDURE
<b>D1</b>	REGLETA CONEXION	CONNECTION BLOCK	BLOC DE CONNEXION
<b>EV1</b>	ELECTROVALVULA VACIO	VACUUM ELECTROVALVE	ELECTROVANNE DE VIDE
<b>EV3</b>	ELECTROVALVULA ELEVACION	LIFT ELECTROVALVE	ÉLECTROVANNE ÉLÉVATION
<b>EV5</b>	ELECTROVALVULA DESCOMPRESION	DECOMPRESSION ELECTROVALVE	ÉLECTROVANNE DE DÉCOMPRESSION
<b>E1</b>	RELE TERMICO	MOTOR RELAY	RALAIS MOTEUR
<b>FUS1</b>	FUSIBLE	FUSE	FUSIBLE
<b>FUS2</b>	FUSIBLE	FUSE	FUSIBLE
<b>I1</b>	INTERRUPTOR GENERAL LUMINOSO	MAIN SWITCH	INTERRUPTEUR GÉNÉRAL
<b>I2</b>	MICRO TAPA	BOARD MICROSWITCH	MICRORRUPTEUR CHOQUE
<b>M</b>	MOTOR	MOTOR	MOTEUR
<b>PC</b>	PLACA DE CONTROL	CONTROL CARD	CARTE COMMANDE
<b>R1</b>	RESISTENCIA SOLDADURA	SEAL ELEMENT	RÉSISTACE DE SOUDURE
<b>R2</b>	RESISTENCIA SOLDADURA	SEAL ELEMENT	RÉSISTACE DE SOUDURE
<b>TCL</b>	TECLADO	KEYBOARD	CLAVIER
<b>TRF2</b>	TRANSFORMADOR SOLDADURA	SEAL TRANSFORMER	TRANSFORMATEUR DE SOUDURE
<b>TRF3</b>	TRANSFORMADOR SOLDADURA	SEAL TRANSFORMER	TRANSFORMATEUR DE SOUDURE
<b>VDR</b>	VARISTOR	VARISTOR	VARISTOR

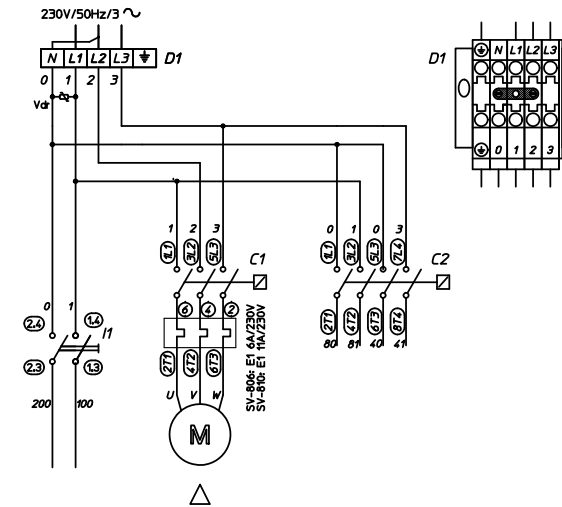
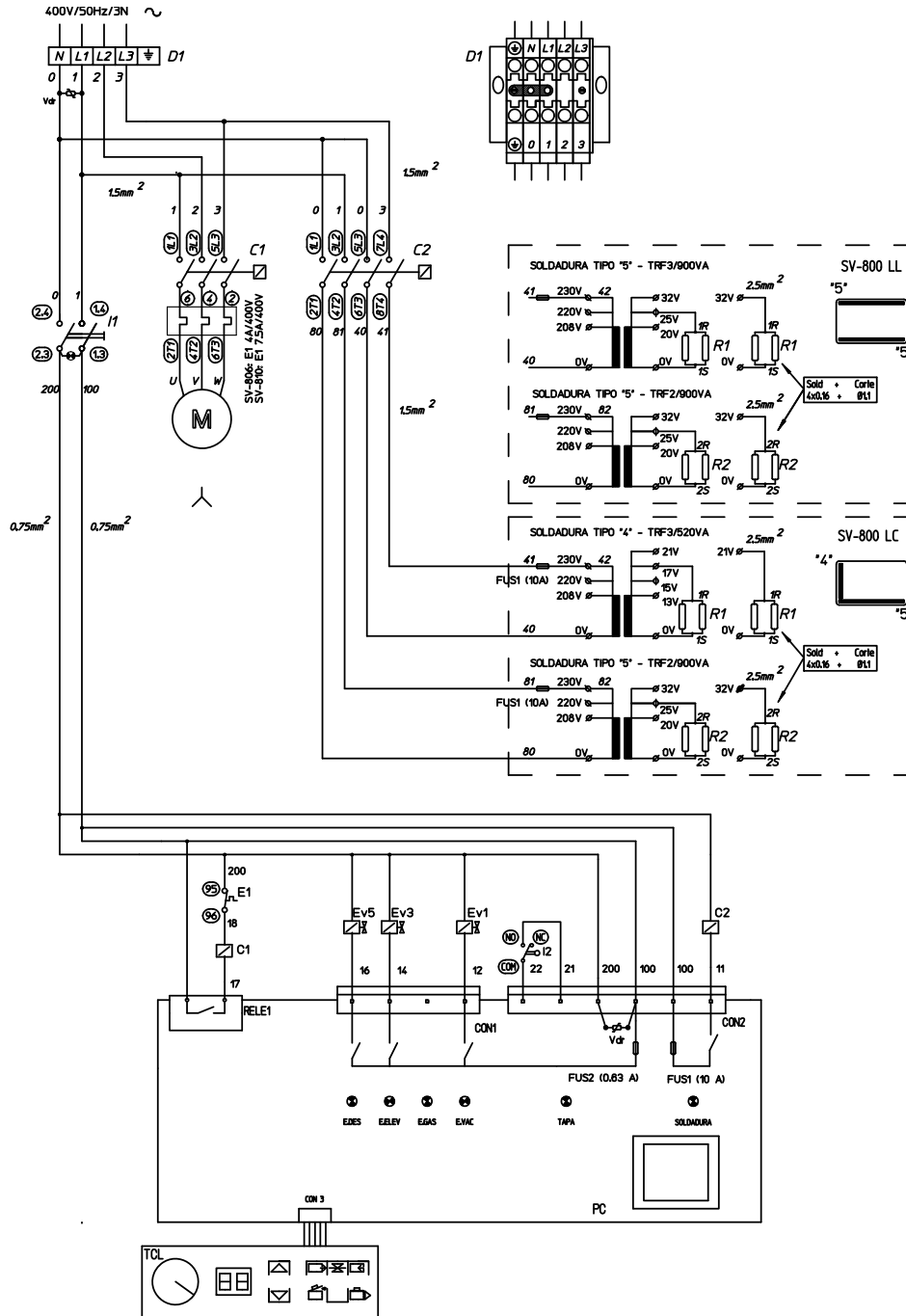

**CAMBIO DE TENSION 400V/230V**  
 1-Desconectar el neutro de la regleta de conexiones y conectar el puente suministrado.  
 2-Conectar el bloque de conexiones del motor segun indica la caja de bones.  
 3-Ajustar el rele termico.

**MOTOR:**  
 SV-806: 15 kW  
 SV-810: 2.2 kW