

	Denominación	Description	Denomination
<b>C</b>	CONDENSADOR MOTOR	MOTOR CAPACITOR	MOTEUR CONDENSATEUR
<b>D1</b>	REGLETA CONEXION	CONNECTION BLOCK	BLOC DE CONNEXION
<b>EV2</b>	ELECTROVALVULA GAS	GAS ELECTROVALVE	ELECTROVALVE GAZ
<b>EV3</b>	ELECTROVALVULA ELEVACION	LIFT ELECTROVALVE	ÉLECTROVANNE ÉLÉVATION
<b>EV4</b>	ELECTROVALVULA ATMOSFERA PROGRESIVA	SOFT AIR ELECTROVALVE	ELECTROVALVE D'ATM. PROGRESSIVE
<b>EV5</b>	ELECTROVALVULA DESCOMPRESION	DECOMPRESSION ELECTROVALVE	ÉLECTROVANNE DE DÉCOMPRESSION
<b>FUS1</b>	FUSIBLE	FUSE	FUSIBLE
<b>FUS2</b>	FUSIBLE	FUSE	FUSIBLE
<b>I1</b>	INTERRUPTOR GENERAL LUMINOSO	MAIN SWITCH	INTERRUPTEUR GÉNÉRAL
<b>I2</b>	MICRO TAPA	BOARD MICROSWITCH	MICRORRUPTEUR CHOCHÉ
<b>M</b>	MOTOR	MOTOR	MOTEUR
<b>PC</b>	PLACA DE CONTROL	CONTROL CARD	CARTE COMMANDE
<b>R1</b>	RESISTENCIA SOLDADURA	SEAL ELEMENT	RÉSISTANCE DE SOUDURE
<b>TCL</b>	TECLADO	KEYBOARD	CLAVIER
<b>TRF2</b>	TRANSFORMADOR SOLDADURA	SEAL TRANSFORMER	TRANSFORMATEUR DE SOUDURE
<b>VDR</b>	VARISTOR	VARISTOR	VARISTOR

230V/50-60Hz/1 ~

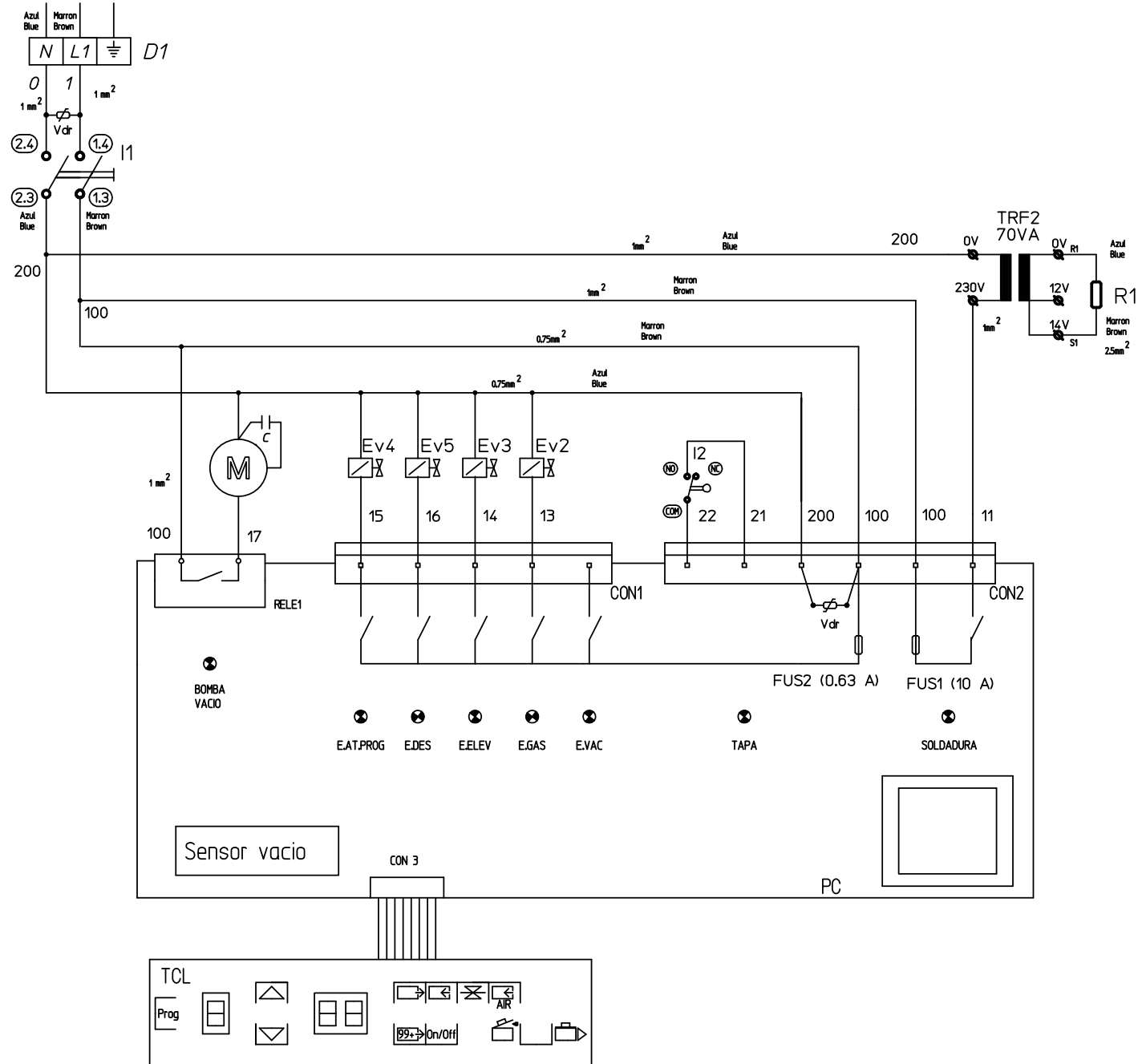

MOTOR  
SV-306S: 0.37 kW  
SV-310S: 0.37 kW