

8. EXPLODED VIEW AND PARTS LIST

Main body Parts-1

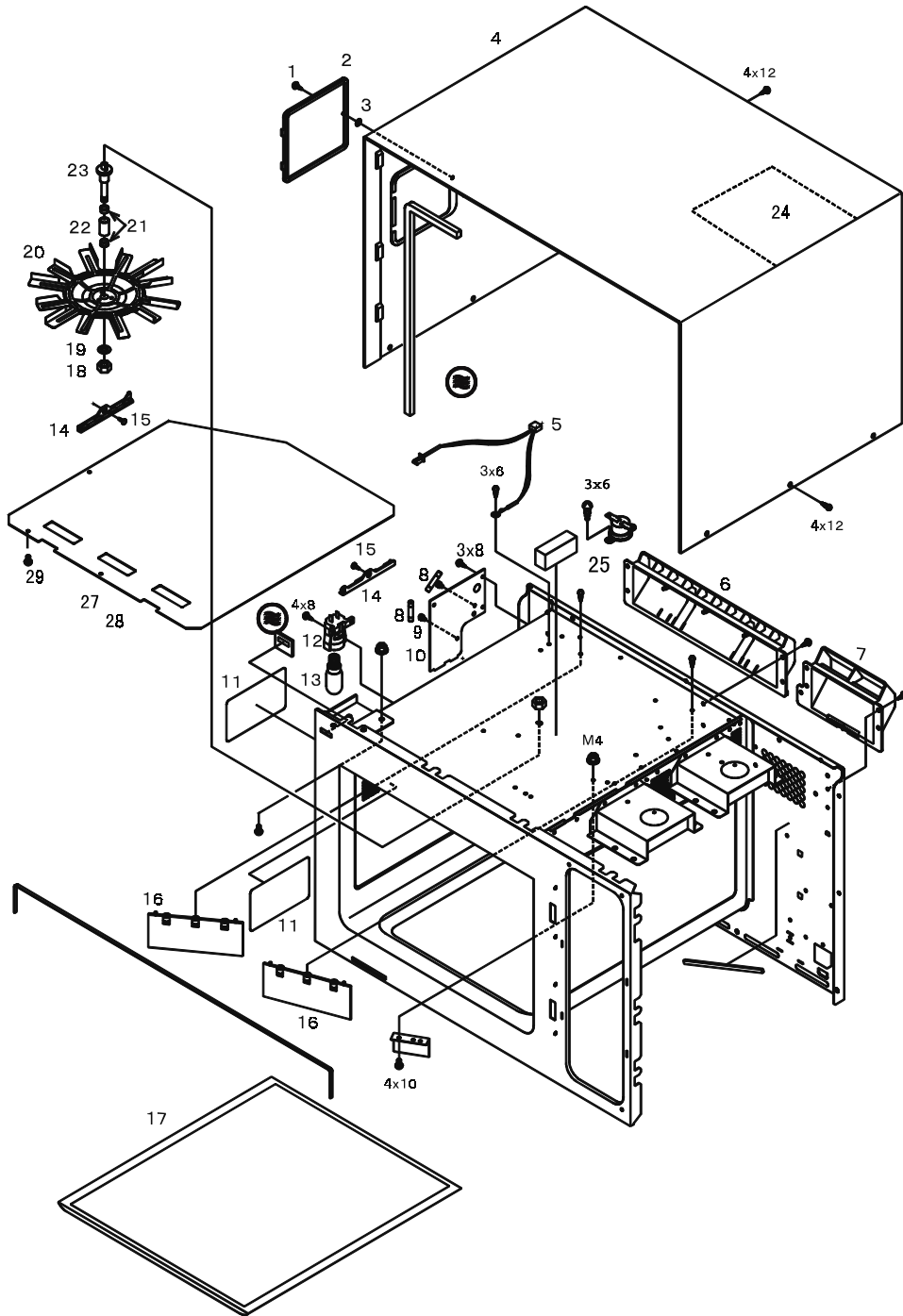

Parts marked with this sign are supplied with high voltage exceeding 250V



Parts marked with this sign have special Characteristics important for microwave leakage. When replacing any of these parts use only Manufacturers specified parts.

Main body Parts-1

KEY NO.	SERVICE PART NO.	DESCRIPTION	QTY.
1	411 075 5300	SCR TPG OVL 3X8	1
2	617 055 9584	FRAME PLATE ASS'Y	1
3	412 018 3803	NUT HEX+CON-SW 2X10	1
4	617 065 5316	FRAME	1
5	617 224 8981	THERMISTOR ASS'Y	1
6	617 059 1966	DUCT ASS'Y	1
7	617 075 2657	COVER KIT, EXHAUST DUCT	1
8	423 018 7609	FUSE 250V 10A	2
9	617 207 6836	CLIP	2
10	617 206 7506	P.C.B COMP. NOISE FILTER	1
11	617 111 2337	LAMP PLATE	2
12	617 077 6356	LAMP SOCKET	1
13	617 149 3009	LAMP	1
14	617 080 6336	CANOE CLIP	1
15	617 074 1729	CAVITY COVER GUIDE	1
16	617 074 5062	STIRRER GUIDE	2
17	617 145 0033	SHELF ASS'Y	1
18	411 055 1407	NUT HEX 8	1
19	617 080 4844	SPECIAL WASHER, 8.5X16X0.5 TO.5XD16.5XD8.5	1
20	617 126 5491	STIRRER FAN	1
21	617 074 4140	STIRRER SHAFT BOSS	2
22	617 181 3135	STIRRER SHAFT BOSS	1
23	617 074 4331	STIRRER SHAFT	1
24	617 137 3639	INSU. SHEET	1
25	617 133 5569	THERMOSTAT 122C	1
26	411 004 5203	NUT HEX 8	1
27	617 058 4944	STIRRER COVER, SD	1
28	617 227 0937	STIRRER COVER, UK	1
29	617 080 3601	SPECIAL SCREW 4X8	1

Main body Parts-2

KEY NO.	SERVICE PART NO.	DESCRIPTION	QTY
1	617 208 1472	CORD ASS'Y,SD	KABELMETAL H07RN-F 1
2	617 196 9184	CORD ASS'Y, UK	1
3	617 140 1349	BOTTOM BRACKET,SD	LGD T1.2 60160 1
4	617 125 3832	BOTTOM BRACKET,UK	1
5	617 131 3789	RELAY	1
6	617 195 1301	H.V.CAPACITOR	MTST 1.30 2.4KV VDE 2
7	415 002 6804	MAGNETRON 2M248J(M)	2
8	617 140 1257	THERMOSTAT 150C	2
9	617 130 3728	BLOWER COMP.	BM-1500UK 2
10	411 074 0207	SCR TPG PAN+FLG 3X30	1
11	411 045 3909	SCR PAN+SW 3X20	2
12	412 025 0000	SCREW PAN 4X12	4
13	617 004 5575	MICRO SWITCH MONITOR	YAMATAKE V-5220DZ 1
14	617 078 1091	SWITCH SHEET	POLYCARBONATE 1
15	617 143 3548	MICRO SWITCH MONITOR	1
16	617 215 8662	MICRO SWITCH DOOR SENSING	V-5232D-157 YAMATAKE 1
17	617 068 2770	LATCH LEVER	1
18	617 068 1834	LEVER STOPPER	1
19	411 054 1606	NUT HEX+FLG W/SRT 3	2
20	411 045 4401	SCR PAN+SW 3X30	2
21	617 124 2294	MICRO SWITCH,LATCH	YAMATAKE V-5130D 2
22	617 068 2718	LATCH LEVER	1
23	617 068 1803	LEVER STOPPER	1
24	617 140 1332	CORD BUSH,SD	SR-31-2 1
25	617 195 1295	SPECIAL WASHER	BRASS T1.0 NI PLATIN 1
26	617 143 3470	PACKING MAGNETRON	CR 2
27	617 143 3456	DUCT	P.P GF20%(V-7100) 2
28	617 078 3132	CORD BUSH,UK	1
29	617 181 2206	FERRITE	HF70RU-16-28-9 4
30	617 145 6639	INSULATION SHEET	1

Microwave Parts

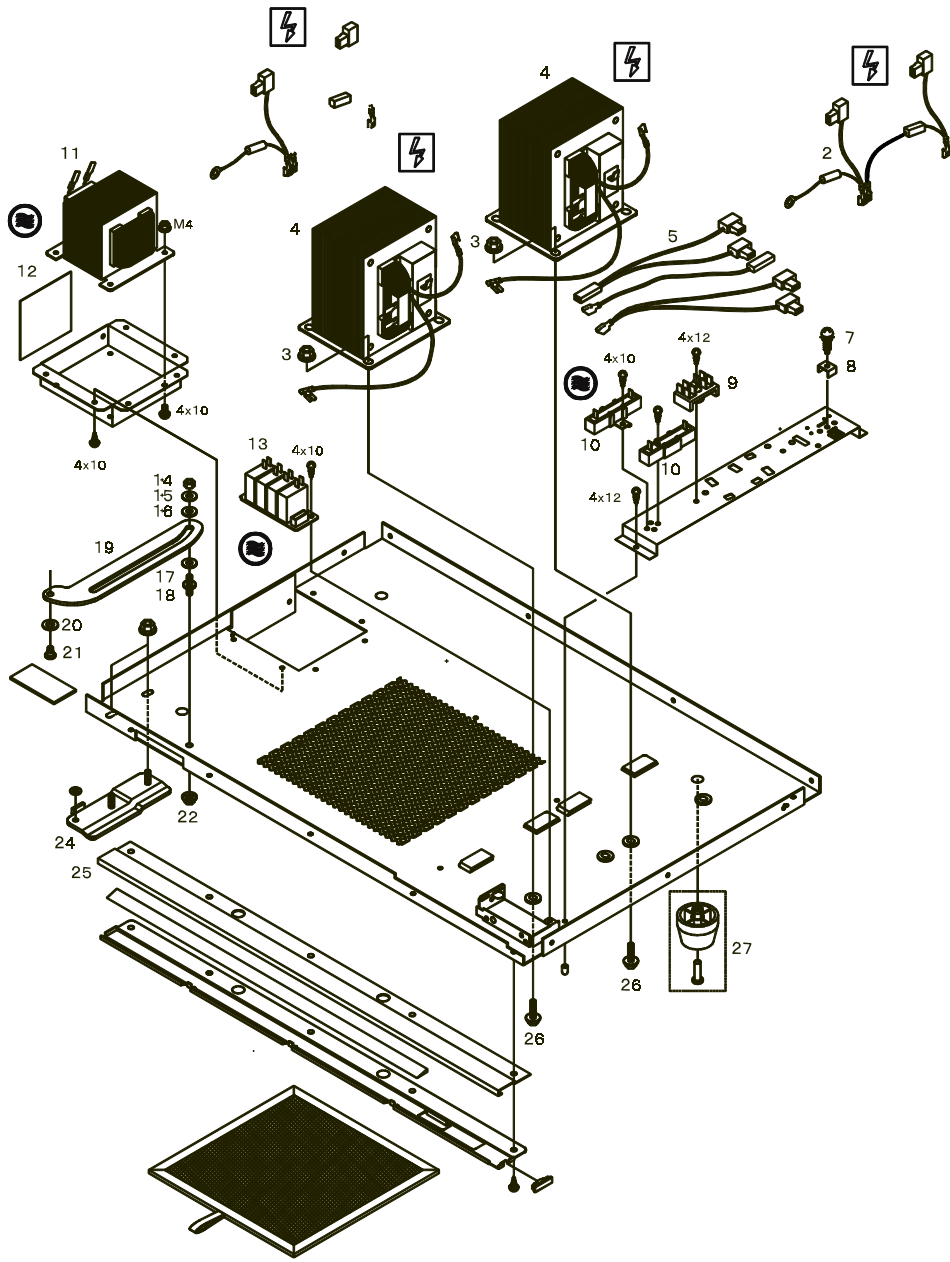

 Parts marked with this sign are supplied with high voltage exceeding 250V

 Parts marked with this sign have special Characteristics important for microwave leakage. When replacing any of these parts use only Manufacturers specified parts.

Microwave Parts

KEY NO.	SERVICE PART NO.	DESCRIPTION	QTY.
1	617 183 6004	HARNESS WITH HV DIODE	1
2	617 183 6288	HARNESS WITH HV DIODE	1
3	411 004 3506	NUT HEX+FLG W/SRT 5	4
4	617 178 3124	HIGH VOLTAGE TRANSFORMER N5T-C2000SD	2
5	617 224 9018	HARNESS NOISE FILTER	1
8	617 195 1295	SPECIAL WASHER BRASS T1.0 NI PLATIN	1
9	617 192 2110	TERMINAL PLATE	1
10	402 061 1505	CERAMIC RES 25 J 20W MTST ERF-20HMJ250	2
11	617 178 2325	POWER TRANS (REACTOR) HLT-10MH	1
12	617 078 2210	INSU. SHEET	1
13	617 202 0150	P.C.B COMP. RELAY	1
14	411 004 3506	NUT HEX+FLG W/SRT 5	1
15	617 080 5186	SPECIAL WASHER SPG T1.0XD5XD13	1
17	617 080 5179	SPECIAL WASHER	2
18	617 080 3830	SPECIAL SCREW	1
19	617 068 3623	DOOR ARM	1
20	617 080 5179	SPECIAL WASHER	1
21	617 080 3847	SPECIAL SCREW SUS-304 D6	1
22	411 055 0202	NUT HEX 5	1
24	617 057 4501	HINGE ASS'Y	1
25	617 056 1501	BOTTOM B.C.T ASS'Y	1
26	617 102 7495	SPECIAL SCREW CAP TIGHT SELLATIONS	4
27	617 056 1594	FOOT CUSHION ASS'Y NIFCO	4
28	617 059 1737	FILTER ASS'Y	1

Door Parts

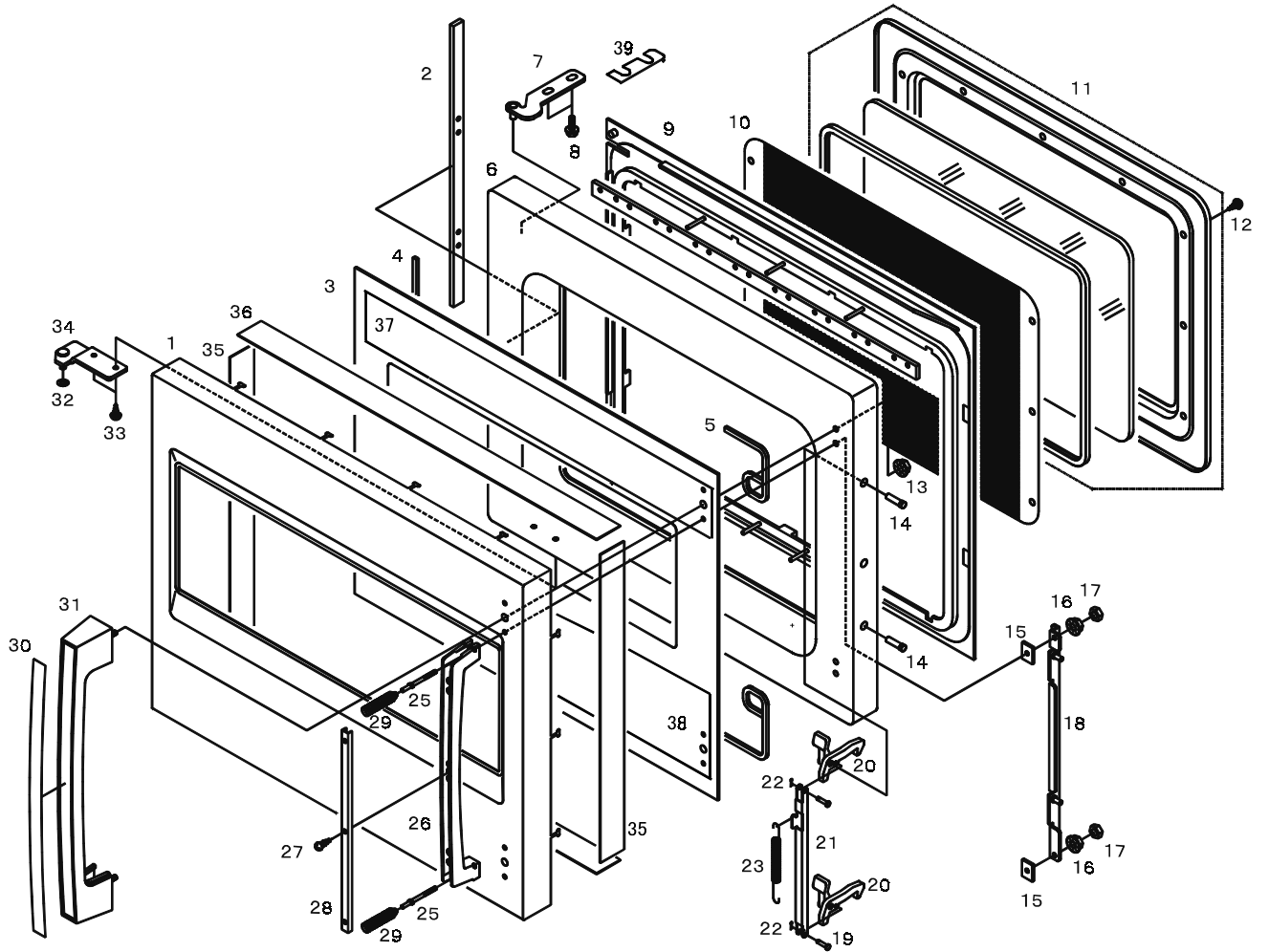

Door Parts

KEY NO.	SERVICE PART NO.	DESCRIPTION	QTY.
1	617 226 4059	DOOR COVER ASS'Y	1
2	617 073 6954	CAVITY GASKET	1
3	617 224 8660	DOOR PANEL (PLASTIC)	1
4	617 150 6167	PACKING	1
5	617 150 6150	PACKING	1
6	617 056 2935	DOOR MAIN FRAME	1
7	617 057 4518	HINGE ASS'Y	1
8	412 018 2103	BOLT HEX C-SCT 5X16	2
9	617 227 0920	CHOKE DIELECTRIC ASS'Y	1
10	617 067 5918	PUNCHING PLATE PERFORATED SCREEN	1
11	617 158 7265	PUNCHING PLATE ASS'Y	1
12	411 051 3108	SCR TRS 4X8	12
13	411 054 1705	NUT HEX+FLG W/SRT 4 S RONA M4 Z1	2
14	617 068 3555	ARM PIN S30C Z1	2
15	617 149 9728	CAVITY G.	2
16	411 054 1606	NUT HEX+FLG W/SRT 3	2
17	411 004 4404	NUT HEX 3	2
18	617 057 3771	LATCH LEVER ASS'Y	1
19	617 068 3562	ARM PIN SUS-430 D3X13	2
20	617 068 0998	DOOR LATCH	2
21	617 068 2671	LATCH LEVER	1
22	411 005 0108	R PIN	2
23	617 080 9146	SPRING SUS-304 D1.2	1
25	617 224 8646	LATCH PIN	2
26	617 224 8639	HANDLE LEVER	1
27	411 070 6005	SCREW TPG BIN 3X6	3
28	617 080 6947	STAY PLATE KBEC45 T1.0X225X18X	1
29	617 080 8316	SPRING, DOOR HANDLE SUS-304WPA	2
30	617 067 9039	DOOR HANDLE COVER	1
31	617 224 8622	DOOR HANDLE	1
32	617 028 8040	SPECIAL WASHER SUS304 D5.5XD14XT0.8	1
33	411 050 7206	SCR TRS 4X10	2
34	617 057 5720	HINGE ASS'Y	1
35	617 227 7387	SPACER ASS'Y.	3
36	617 227 7394	SPACER ASS'Y.	1
37	617 227 7363	SPACER ASS'Y.	1
38	617 227 7370	SPACER ASS'Y.	1
39	617 068 6303	HINGE SHIM P.T TO.8	2

Control panel Parts

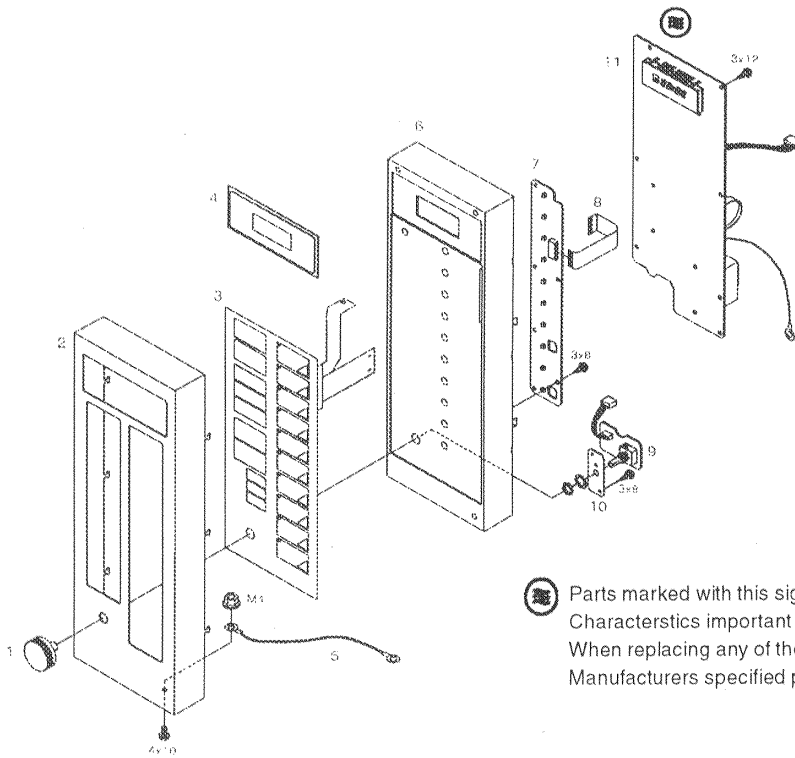

Parts marked with this sign have special Characteristics important for microwave leakage. When replacing any of these parts use only Manufacturers specified parts.

KEY NO.	SERVICE PART NO.	DESCRIPTION	QTY.
1	617 224 8745	KNOB ASS'Y	1
2	617 226 4066	CONTROL COVER	1
3	617 224 8905	KEY BOARD	1
4	617 226 4073	CONTROL PLATE.DISPLAY	1
5	617 226 7029	LEAD WIRE ASS'Y.EARTH	1
6	617 224 8776	CONTROL BASE	1
7	617 221 2425	P.C.B COMP.DISPLAY	1
8	617 164 9307	FLAT CABLE	1
9	617 224 8806	SWITCH ASS'Y PCB COMP	1
10	617 213 8596	PARTS BASE SWITCH	1
11	617 221 2418	P.C.B COMP. CONTROL	1
12	617 224 9070	OPERATING INSTRUCTIONS	1